

- > Port size: 1/8" ... 3/8" (ISO G/NPT)
- > Suitable for vacuum
- > High flow rate
- > Functional compact design
- > Body with M5 fastening thread as standard
- > Solenoid interchangeable without tools (*Click-on*)
- > Valve operates without pressure differential

Click-on

Technical features

Medium:

Neutral gases and liquids

Switching function:

Normally closed

Operation:

Directly solenoid actuated

Mounting position:

Optional, preferably solenoid vertical on top

Flow direction:

Determined

Port size:

G1/8, G1/4, G3/8

1/8 NPT, 1/4 NPT, 3/8 NPT

Operating pressure:

See table

Fluid temperature:

-10° ... +90°C (+14° ... +194°F)

Ambient temperature:

-10° ... +50°C (+14° ... +122°F)

Material:

Body: Brass (CW617N)

Seat seal: NBR

Internal parts: Stainless steel, Brass

For contaminated fluids insertion of a strainer is recommended.

Technical data - Standard models - Valves normally closed

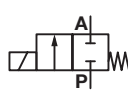
Symbol	Port size	Orifice (mm)	Flow kv value *1) (m³/h)	Operating pressure *2) (bar)	Weight (kg)	Model Solenoid in V d.c. / a.c.
	G1/8	1,5	0,07	0 ... 25	0,33	8251800.9101.xxxxx
	1/8 NPT	1,5	0,07	0 ... 25	0,33	8252800.9101.xxxxx
	G1/4	1,5	0,07	0 ... 25	0,33	8251000.9101.xxxxx
	1/4 NPT	1,5	0,07	0 ... 25	0,33	8252000.9101.xxxxx
	G3/8	1,5	0,07	0 ... 25	0,33	8251100.9101.xxxxx
	3/8 NPT	1,5	0,07	0 ... 25	0,33	8252100.9101.xxxxx
	G1/8	1,5	0,07	0 ... 70	0,57	8251807.9151.xxxxx
	1/8 NPT	1,5	0,07	0 ... 70	0,57	8252807.9151.xxxxx
	G1/4	1,5	0,07	0 ... 70	0,57	8251007.9151.xxxxx
	1/4 NPT	1,5	0,07	0 ... 70	0,57	8252007.9151.xxxxx
	G3/8	1,5	0,07	0 ... 70	0,57	8251107.9151.xxxxx
	3/8 NPT	1,5	0,07	0 ... 70	0,57	8252107.9151.xxxxx
	G1/8	2,5	0,15	0 ... 10	0,33	8251820.9101.xxxxx
	1/8 NPT	2,5	0,15	0 ... 10	0,33	8252820.9101.xxxxx
	G1/4	2,5	0,15	0 ... 10	0,33	8251020.9101.xxxxx
	1/4 NPT	2,5	0,15	0 ... 10	0,33	8252020.9101.xxxxx
	G3/8	2,5	0,15	0 ... 10	0,33	8251120.9101.xxxxx
	3/8 NPT	2,5	0,15	0 ... 10	0,33	8252120.9101.xxxxx
	G1/8	2,5	0,15	0 ... 40	0,57	8251820.9151.xxxxx
	1/8 NPT	2,5	0,15	0 ... 40	0,57	8252820.9151.xxxxx
	G1/4	2,5	0,15	0 ... 40	0,57	8251020.9151.xxxxx
	1/4 NPT	2,5	0,15	0 ... 40	0,57	8252020.9151.xxxxx
	G3/8	2,5	0,15	0 ... 40	0,57	8251120.9151.xxxxx
	3/8 NPT	2,5	0,15	0 ... 40	0,57	8252120.9151.xxxxx

xxxxx Please insert voltage and frequency codes

*1) Cv-value (US) ≈ kv value x 1,2

*2) For gases and liquid fluids up to 25 mm²/s (cSt)

Technical data - Standard models - Valves normally closed

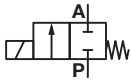
Symbol	Port size	Orifice (mm)	Flow kv value *1) (m ³ /h)	Operating pressure *2) (bar)	Weight (kg)	Typ Solenoid in V d.c. /a.c.
	G1/8	3	0,21	0 ... 4	0,33	8251840.9101.xxxxx
	1/8 NPT	3	0,21	0 ... 4	0,33	8252840.9101.xxxxx
	G1/4	3	0,21	0 ... 4	0,33	8251040.9101.xxxxx
	1/4 NPT	3	0,21	0 ... 4	0,33	8252040.9101.xxxxx
	G3/8	3	0,21	0 ... 4	0,33	8251140.9101.xxxxx
	3/8 NPT	3	0,21	0 ... 4	0,33	8252140.9101.xxxxx
	G1/8	3	0,21	0 ... 20	0,57	8251840.9151.xxxxx
	1/8 NPT	3	0,21	0 ... 20	0,57	8252840.9151.xxxxx
	G1/4	3	0,21	0 ... 20	0,57	8251040.9151.xxxxx
	1/4 NPT	3	0,21	0 ... 20	0,57	8252040.9151.xxxxx
	G3/8	3	0,21	0 ... 20	0,57	8251140.9151.xxxxx
	3/8 NPT	3	0,21	0 ... 20	0,57	8252140.9151.xxxxx
	G1/8	4	0,35	0 ... 12	0,57	8251860.9151.xxxxx
	1/8 NPT	4	0,35	0 ... 12	0,57	8252860.9151.xxxxx
	G1/4	4	0,35	0 ... 12	0,57	8251060.9151.xxxxx
	1/4 NPT	4	0,35	0 ... 12	0,57	8252060.9151.xxxxx
	G3/8	4	0,35	0 ... 12	0,57	8251160.9151.xxxxx
	3/8 NPT	4	0,35	0 ... 12	0,57	8252160.9151.xxxxx
	G1/8	5	0,5	0 ... 6	0,57	8251880.9151.xxxxx
	1/8 NPT	5	0,5	0 ... 6	0,57	8252880.9151.xxxxx
G1/4	5	0,5	0 ... 6	0,57	8251080.9151.xxxxx	
1/4 NPT	5	0,5	0 ... 6	0,57	8252080.9151.xxxxx	
G3/8	5	0,5	0 ... 6	0,57	8251180.9151.xxxxx	
3/8 NPT	5	0,5	0 ... 6	0,57	8252180.9151.xxxxx	

xxxxx Please insert voltage and frequency codes

*1) Cv-value (US) ≈ kv value x 1,2

*2) For gases and liquid fluids up to 25 mm²/s (cSt)

Technical data - Standard models - Valves normally open

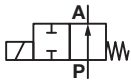
Symbol	Port size	Orifice (mm)	Flow kv value *1) (m ³ /h)	Operating pressure *2) (bar)	Weight (kg)	Model Solenoid in V d.c. / a.c.
	G1/4	1,5	0,07	0 ... 16	0,33	8251001.9101.xxxxx
	1/4 NPT	1,5	0,07	0 ... 16	0,33	8252001.9101.xxxxx
	G1/4	2,5	0,15	0 ... 6	0,33	8251021.9101.xxxxx
	1/4 NPT	2,5	0,15	0 ... 6	0,33	8252021.9101.xxxxx
	G1/4	2,5	0,15	0 ... 25	0,57	8251021.9151.xxxxx
	1/4 NPT	2,5	0,15	0 ... 25	0,57	8252021.9151.xxxxx
	G1/4	3	0,21	0 ... 3	0,33	8251041.9101.xxxxx
	1/4 NPT	3	0,21	0 ... 3	0,33	8252041.9101.xxxxx
	G1/4	3	0,21	0 ... 16	0,57	8251041.9151.xxxxx
	1/4 NPT	3	0,21	0 ... 16	0,57	8252041.9151.xxxxx
	G1/4	4	0,35	0 ... 8	0,57	8251061.9151.xxxxx
	1/4 NPT	4	0,35	0 ... 8	0,57	8252061.9151.xxxxx

xxxxx Please insert voltage and frequency codes

*1) Cv-value (US) ≈ kv value x 1,2

*2) For gases and liquid fluids up to 25 mm²/s (cSt)

Option selector
825***.*****.*******

Thread form	Substitute
ISO G	1
NPT	2
Port size	Substitute
1/8"	8
1/4"	0
3/8"	1
Valve options	Substitute
Normally closed (NC), DN 1,5 Operating pressure 0 ... 25 bar (with solenoid 9101)	00
Normally open (NO), DN 1,5 Operating pressure 0 ... 16 bar (with solenoid 9101)	01
Normally closed (NC), DN 1,5 Operating pressure 0 ... 70 bar (with solenoid 9151)	07
Normally closed (NC), DN 2,5 Operating pressure 0 ... 10 bar (with solenoid 9101)	20
Normally closed (NC), DN 2,5 Operating pressure 0 ... 40 bar (with solenoid 9151)	20
Normally open (NO), DN 2,5 Operating pressure 0 ... 6 bar (with solenoid 9101)	21
Normally open (NO), DN 2,5 Operating pressure 0 ... 25 bar (with solenoid 9151)	21
Normally closed (NC), DN 3 Operating pressure 0 ... 4 bar (with solenoid 9101)	40
Normally closed (NC), DN 3 Operating pressure 0 ... 20 bar (with solenoid 9151)	40
Normally open (NO), DN 3 Operating pressure 0 ... 3 bar (with solenoid 9101)	41
Normally open (NO), DN 3 Operating pressure 0 ... 16 bar (with solenoid 9151)	41
Normally closed (NC), DN 4 Operating pressure 0 ... 12 bar (with solenoid 9151)	60
Normally open (NO), DN 4 Operating pressure 0 ... 8 bar (with solenoid 9151)	61
Normally closed (NC), DN 5 Operating pressure 0 ... 6 bar (with solenoid 9151)	80

Frequency	Substitute
See table frequency codes	xx
Voltage	Substitute
See Voltage codes	xxx
Solenoid options	Substitute
Solenoid 9101	9101
Solenoid 9151	9151

Standard solenoid systems

Voltage and Frequency Solenoid 9101 *1)					
Code	Code	Voltage	Frequency	Power consumption	
Voltage	Frequency			Inrush	Holding
024	00	24 V d.c.	-	8 W	8 W
024	50	24 V a.c.	50 Hz	15 VA	12 VA
110	50	110 V a.c.	50 Hz	15 VA	12 VA
120	60	120 V a.c.	60 Hz	15 VA	12 VA
230	50	230 V a.c.	50 Hz	15 VA	12 VA
Voltage and Frequency Solenoid 9151 *1)					
024	00	24 V d.c.	-	18 W	18 W
024	50	24 V a.c.	50 Hz	45 VA	35 VA
110	50	110 V a.c.	50 Hz	45 VA	35 VA
120	60	120 V a.c.	60 Hz	45 VA	35 VA
230	50	230 V a.c.	50 Hz	45 VA	35 VA

Electrical details for all solenoid systems

Design	DIN VDE 0580
Voltage range	±10%
Duty cycle	100% ED
Protection class	EN 60529 IP65
Socket	Form A acc. to DIN EN 175301-803 (included)

According to DIN VDE 0580 at a solenoid temperature of +20°C.
 At operating state temperature the input power of a coil decreases by up to ca. 30%
 due to physical reasons.

Further versions on request!

 *1) c_{US} coil only

Section view

G1/8 ... 3/8

Solenoid 9101

Solenoid 9151

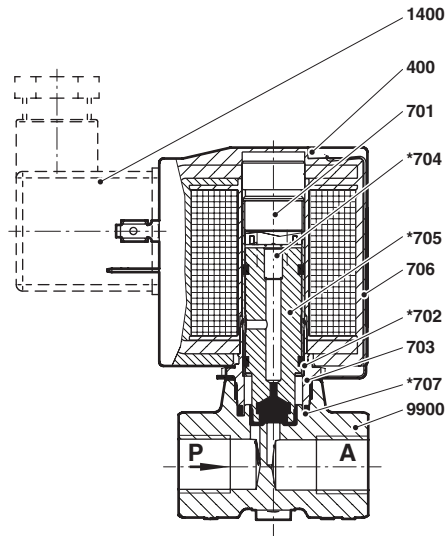
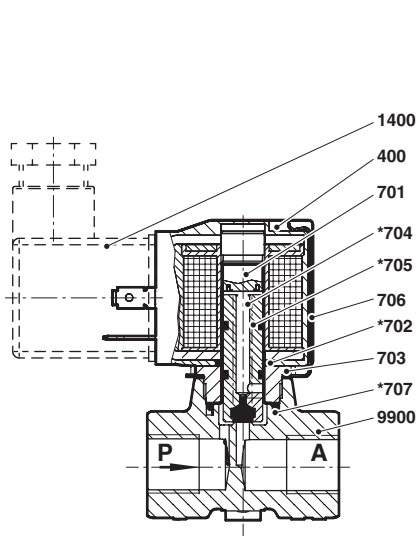

No.	Description
400	Solenoid
701	Core tube
702	O-ring
703	Screw piece
*704	Pressure spring
*705	Plunger
706	Spring clip
*707	O-ring
1400	Socket (included)
9900	Valve body

* These individual parts form a complete wearing unit.
When ordering spare parts please state Model No. and Series No.

Dimensions
Solenoid 9101

Dimensions in mm
Projection/First angle

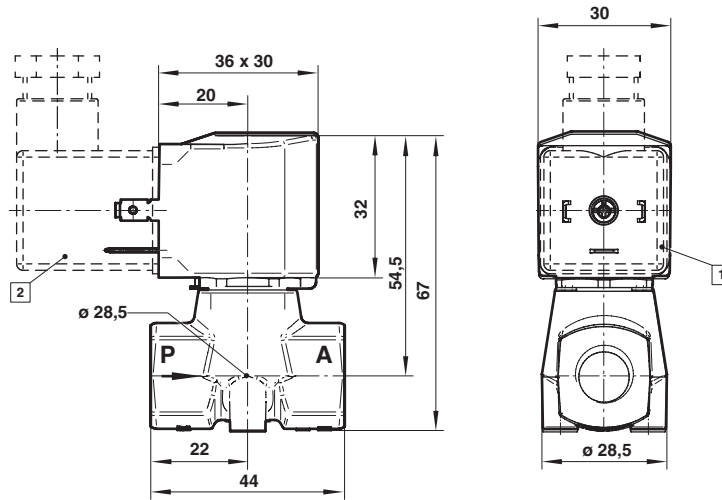

Solenoid 9151

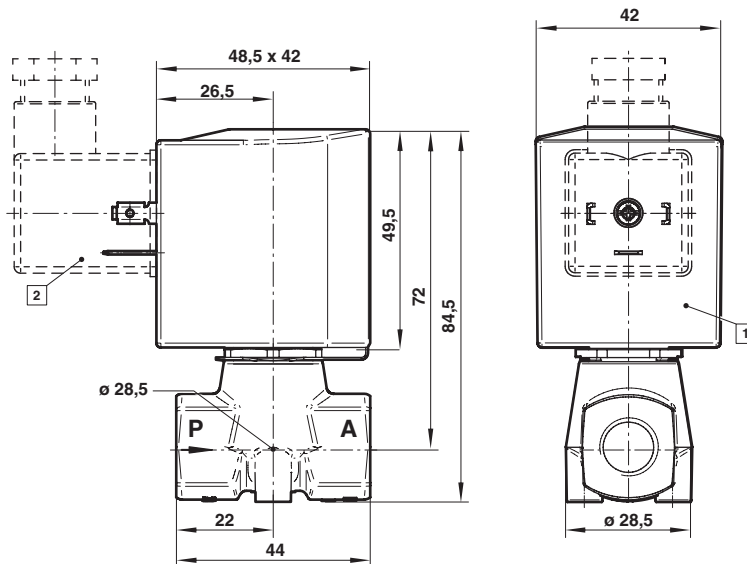

- 1 Solenoid rotatable 360°
- 2 Socket turnable 4 x 90°
(Socket included)

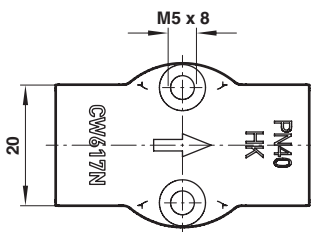

Note to Pressure Equipment Directive (PED):

The valves of this series are according to Art. 3 § 3 of the Pressure Equipment Directive (PED) 97/23/EG. This means interpretation and production are in accordance to engineers practice well-known in the member countries.

The CE-sign at the valve does not refer to the PED. Thus the declaration of conformity is not longer applicable for this directive.

Note to Electromagnetic Compatibility Guideline (EEC):

The valves shall be provided with an electrical circuit which ensures the limits of the harmonised standards EN 61000-6-3 and EN 61000-6-1 are observed, and hence the requirements of the Electromagnetic Compatibility Guideline (2004/108/EEC) satisfied.