

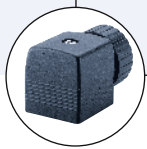

2/2-way Solenoid Valve for aggressive media, true union, Ø20-63

- Isolating diaphragm between the solenoid and fluid
- Non-metallic valve internals
- Pivoted armature, with lockable manual override
- Simple installation and removal

Type 0142 can be combined with...



Type 2508

Cable plug



Type 1078

Timer unit

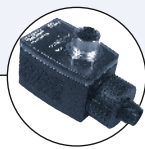

Type 2511/12

ASI cable plug

Servo-assisted solenoid valve with diaphragm, normally closed function. Hermetic isolation of fluid from the actuator. A minimum differential pressure of 0.5 bar is required to fully open the valve.

Valves can be mounted or removed radially for a space-saving installation.

Circuit function A

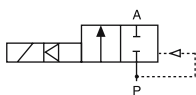

2/2- way valve, normally closed, with 3-way pilot servo-assistance

Technical data	
Orifice	DN 15 - 50
Body material	PVC, PVDF (on request)
Inner part valve	PVDF
Seal material	FKM, EPDM
Media with EPDM with FKM	Alkalis, alkaline washing and bleaching lyes Oxydizing acids and substances, salt solutions
Media temperature PVC-body PVDF-body	0 to +50°C 0 to +70°C
Ambient temperature PVC-body PVDF-body	0 to +40°C 0 to +55°C
Voltage tolerance	±10%
Duty cycle	100% continuous rating
Electrical connection	Cable plug for Ø 7 mm acc. to DIN EN 175301-803 Form A (supplied as standard)
Protection class	IP 65 with cable plug
Coil insulation class	Class H
Port connection	True union
Installation	as required, preferably with actuator upright

Power consumption			
Inrush		Hold (hot coil)	
AC [VA]	DC [W]	AC [VA/W]	DC [W]
20	5	11/5	5

Response times ¹⁾	
Opening [ms]	100 - 800
Closing [ms]	1000 - 4000

¹⁾ Measured at valve outlet at 6 bar and +20°C acc. to ISO 12238.

Opening: Pressure rise 0 to 90%, Closing: Pressure drop 100 to 10%

Materials

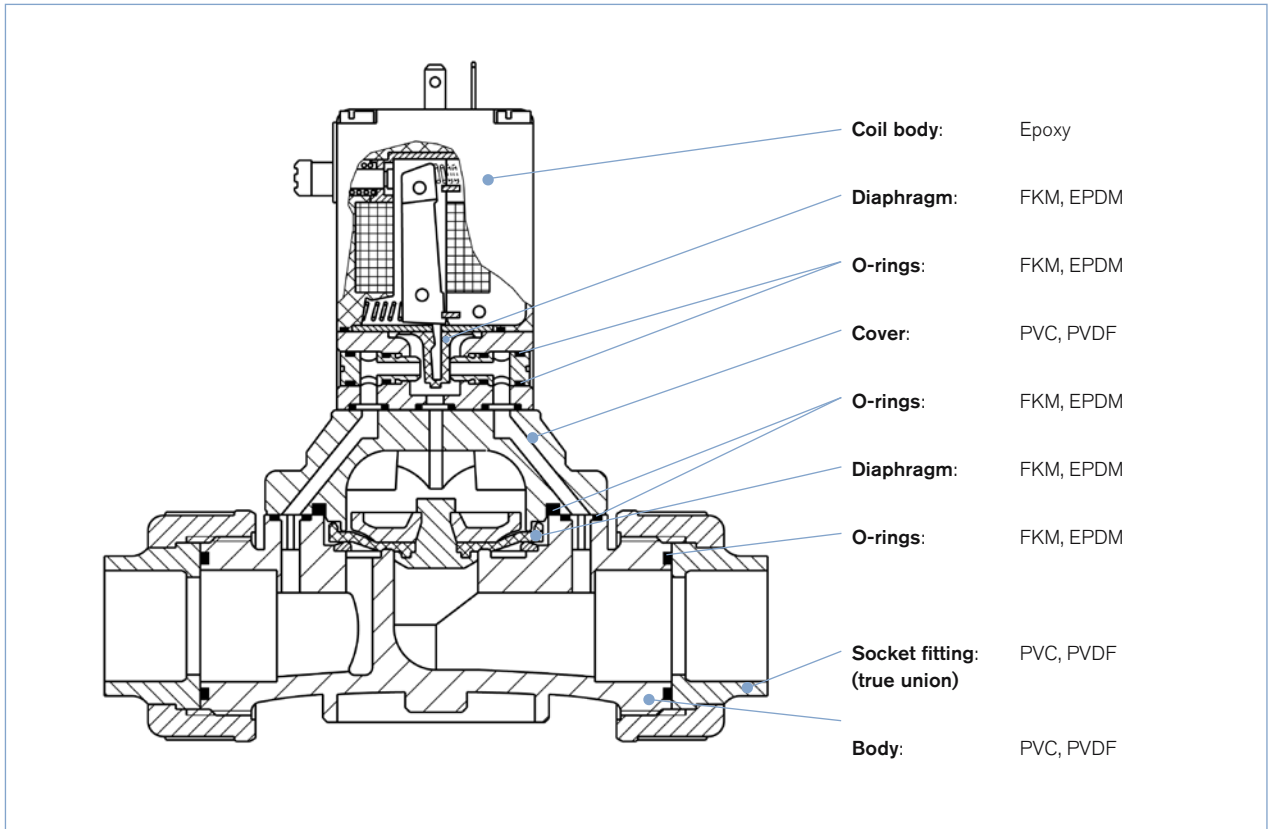

Pressure-Temperature-chart for PVC and PVDF

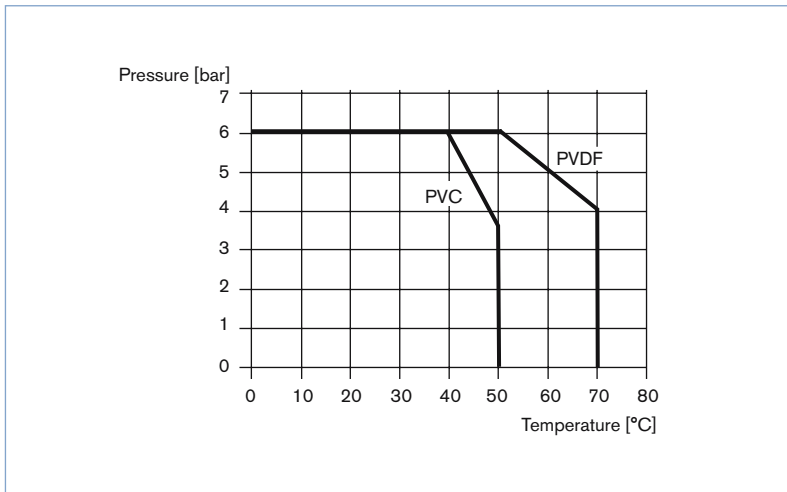

Ordering chart for valves (other versions on request)

PVC-body with cable plug and manual override

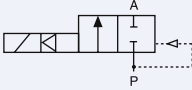
Circuit function	Port connection True union	Orifice (mm)	Kv-value water [m ³ /h]	Pressure range [bar]	Body material	Item no. per voltage/frequency [V/Hz]		
						024/DC	230/50	
A  2/2- way valve, normally closed, with 3-way pilot servo-assistance	Seal material FKM							
	Ø 20	15	5.0	0,5 - 6	PVC	041 938	041 934	
	Ø 25	20	6.0	0,5 - 6	PVC	042 008	042 005	
	Ø 32	25	14.0	0,5 - 6	PVC	042 079	042 113	
	Ø 40	32	16.0	0,5 - 6	PVC	042 169	042 133	
	Ø 50	40	30.0	0,5 - 6	PVC	042 198	042 245	
	Ø 63	50	36.0	0,5 - 6	PVC	042 264	042 262	
	Seal material EPDM							
	Ø 20	15	5.0	0,5 - 6	PVC	041 980	041 911	
	Ø 25	20	6.0	0,5 - 6	PVC	042 045	041 986	
	Ø 32	25	14.0	0,5 - 6	PVC	042 047	042 126	
	Ø 40	32	16.0	0,5 - 6	PVC	042 183	042 128	
	Ø 50	40	30.0	0,5 - 6	PVC	042 195	042 247	
	Ø 63	50	36.0	0,5 - 6	PVC	042 266	042 261	

 Further versions on request

 **Materials**
 Body material PVDF

 **Port connection**
 With threaded port

 **Circuit function**
 B, normally open

 Feedback switch

Dimensions [mm]

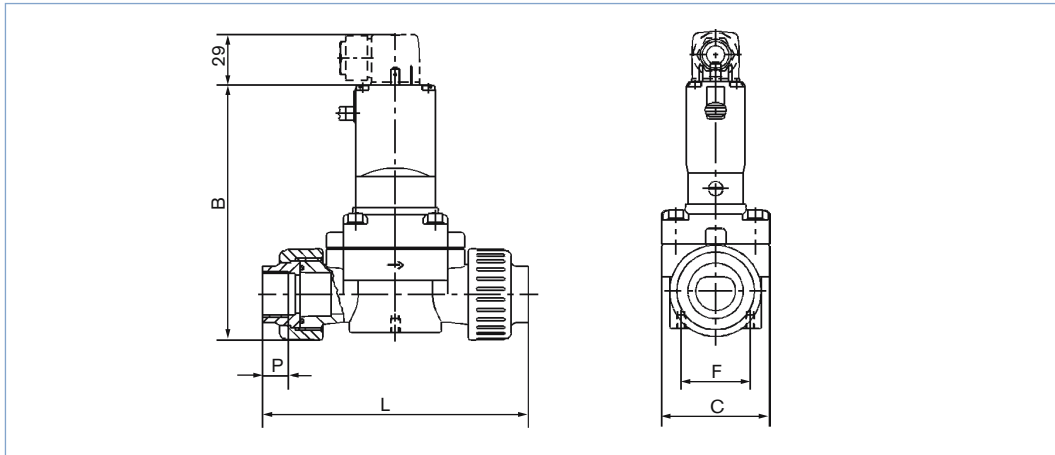

All versions					PVC-body		PVDF-body	
DN	Pipe Ø	B	C	F	L	P	L	P
15	20	148	62.5	40	148	16	147	16
20	25	148	62.5	40	154	19	151	18
25	32	174.5	85	44.5	190	22	185	20
32	40	174.5	85	44.5	198	26	189	22
40	50	212	115	44.5	254	31	245	25
50	63	212	115	44.5	268	38	253	29

To find your nearest Bürkert facility, click on the orange box →

www.burkert.com

In case of special application conditions,
please consult for advice.

We reserve the right to make technical
changes without notice.

0802/2_EU-en_00891606