

- > **Port size:**
1/4 NPT, 1/2 NPT
- > **Suitable for marine, offshore, food processing and dental applications Model for precision regulation and high flow rates**
- > **Reliable and long life, ideal for one time installation**
- > **Certification: ATEX & TR CU (EAC) for non electrical equipment**



Technical features

Medium:

Compressed air

Operating pressure:

20 bar (290 psi) maximum

Outlet pressure range:

Standard:

0,5 ... 10 bar (7 ... 145 psi)

Optional:

0,5 ... 6/16 bar (7 ... 87/232 psi)

Flow characteristics:

See page 2

Element:

Standard: 40 ... 50 µm

Optional: 5 ... 10 µm, 20 ... 30 µm

Port sizes:

Standard: 1/4 NPT, 1/2 NPT

1/8 NPT (gauge)

Optional:

G1/4 or G1/2; G1/8 (gauge)

Relief port:

ø 2 mm

Drain:

Manual or automatic

Fluid/Ambient temperature:

Standard:

-30 ... +90°C (-22 ... +194°F)

Optional:

-55 ... +90°C (-67 ... +194°F)

Air supply must be dry enough to avoid ice formation at temperatures below +2°C (+35°F).

Materials:

Valve body, top & bottom covers,

valve trim: 316 stainless steel

Seat and spring: stainless steel

O-rings, seals and diaphragm:

NBR

See option selector for variants

Technical data, standard model, relieving

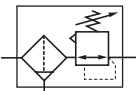
Symbol	Port size	Outlet pressure *1) (bar)	Element (µm)	Flow *2) (dm³/s)	Drain	Weight (kg)	Model
	1/4 NPT	0,5 ... 10	40 ... 50	65	Manual	1,80	YR2ACA1H0BS040
	1/2 NPT	0,5 ... 10	40 ... 50	160	Manual	2,20	YR2ACA3H0BS040

*1) Outlet pressure can be adjusted to pressures in excess of, and less than, those specified.

Do not use these units to control pressures outside of the specified ranges.

*2) Typical flow with 10 bar (145 psi) inlet pressure, 6,3 bar (91 psi) set pressure and a 1 bar (14 psi) drop from set.

Option selector

YR2★★★★★S0★★

Outlet pressure range	Substitute					Filter element	Substitute
0,5 ... 10 bar (standard)	A					40 ... 50 µm (standard)	40
0,5 ... 16 bar	B					20 ... 30 µm	20
0,5 ... 6 bar	6					5 ... 10 µm	05
Operation options	Substitute					Mounting	Substitute
Filter/regulator unit automatic drain	A					With mounting bracket (standard)	B
Filter only automatic drain	B					None	N
Filter/regulator unit manual drain	C					Gauge	Substitute
Filter only manual drain	F					None (standard)	0
Regulator only automatic drain	R					304/316SS dry, bar & psi units	1
Regulator only manual drain	M					304/316SS, Glycerine, bar & psi units	2
Port size	Substitute					304/316SS dry, psi & kPa units	3
1/4 NPT (standard)	A1					316/316SS dry, bar & psi units	4
G1/4	E1					316/316SS, Glycerine, bar & psi units	5
1/2 NPT (standard)	A3						
G1/2	E3						
Seat/seal materials	Substitute						
NBR (standard)	H						
FKM	V						
Low temperature variant (-55 ... 90°C)	L						

Flow characteristics

1/4"

1/2"

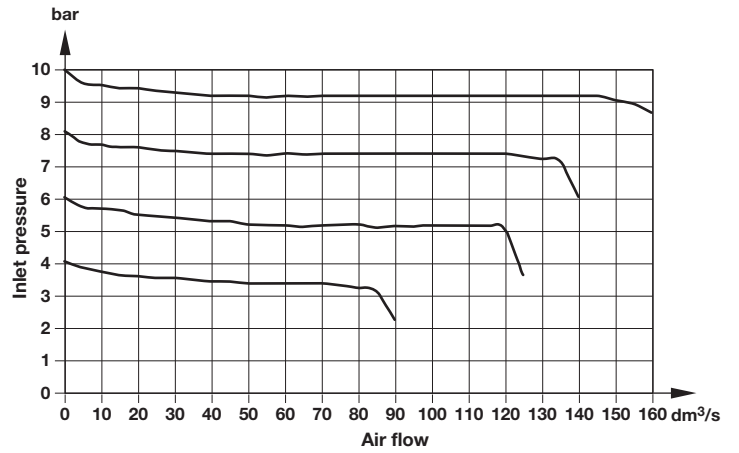
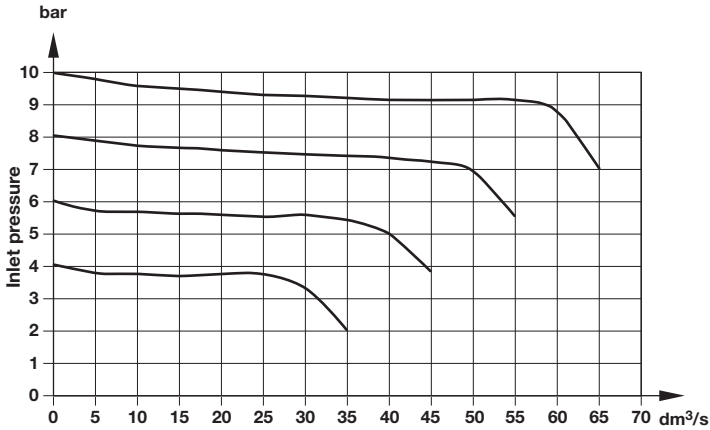

Dimensions

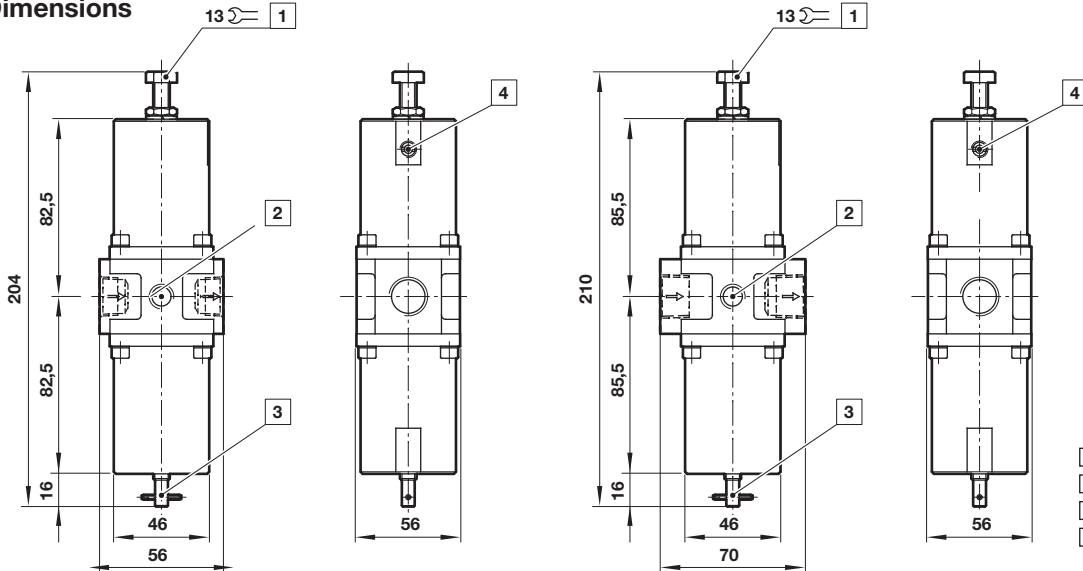

Dimensions in mm
Projection/First angle



- 1 Adjustment screw
- 2 1/8 NPT Gauge port
- 3 Manual drain
- 4 Relief vent ø 2 mm

Bracket mounting kit

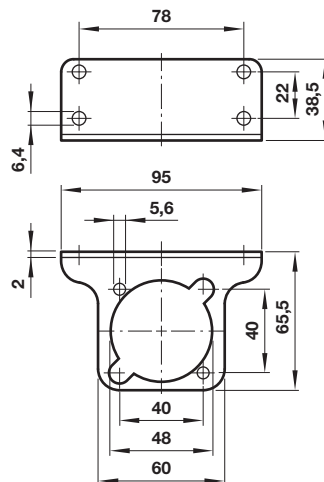

Warning

These products are intended for use in industrial compressed air systems only. Do not use these products where pressures and temperatures can exceed those listed under

»Technical features/data«.

Before using these products with fluids other than those specified, for non-industrial applications, life-support systems or other applications not within published specifications, consult IMI Precision Engineering, Thompson Valves Ltd.

Through misuse, age, or malfunction, components used in fluid power systems can fail in various modes.

The system designer is warned to consider the failure modes of all component parts used in fluid power systems and to provide adequate safeguards to prevent personal injury or damage to equipment in the event of such failure.

System designers must provide a warning to end users in the system instructional manual if protection against a failure mode cannot be adequately provided.

System designers and end users are cautioned to review specific warnings found in instruction sheets packed and shipped with these products.