



Main Features

- Excellent repeatability
- Dead band adjustment for regulation
- Fix dead band for control and alarm
- Overpressure up to 100 bar

Applications

- Energy safety equipment
- Power generation safety equipment
- Pressurized chambers control
- Liquid level control



Technical Data

Pressure range	-1 ... 2.5 bar to 0.2 ... 4 bar	Case	Black Zamak
Temperature	Process: -50 ... +200 °C Ambient: -25 ... +55 °C Storage: -40 ... +70 °C	Mounting	Wall mounting bracket
Repeatability	± 1% F.S. / constant pressure cycle	Ground connection	Via internal terminal block
CE conformity	Low Voltage Directive LVD 2006/95/EC	Electrical connection	Terminal block with plastic cable gland for Ø 7 to 10.5 mm
Protection rating	IP 66 (EN 60529)	Electrical function	See ordering code details in page 5
Process Connection	Stainless steel 1.4404 (316L)	Adjustment	2 external adjustment screws on top of the case for set point and dead band
Sensing element	<u>Pressure range code 201 (RPPN6)</u> Diaphragm: Perbunan® Flanges: Steel, galvanized, bichromate finish <u>Pressure range code 204 to 210 (RPPN8)</u> Diaphragm: Stainless steel 1.4404 (AISI 316L) Fitting: Stainless steel 1.4404 (AISI 316L)		
Scale	Internal. Accuracy on reading ± 5% F.S.		
Cover	Zamak blue painted Captive stainless steel screws		

Options

Customer specific set point adjustment	Code SETP
Oxygen application	Code 0765
Mounting on 2" pipe	Code 0407
Electrical connection: stainless steel connector (Souriau)	Code 2298
Mobile plug for stainless steel connector (Souriau)	Code 2249
Stainless steel tag plate and wire	Code 9941
Lead seal of the adjustment screws	Code 8990

Principle

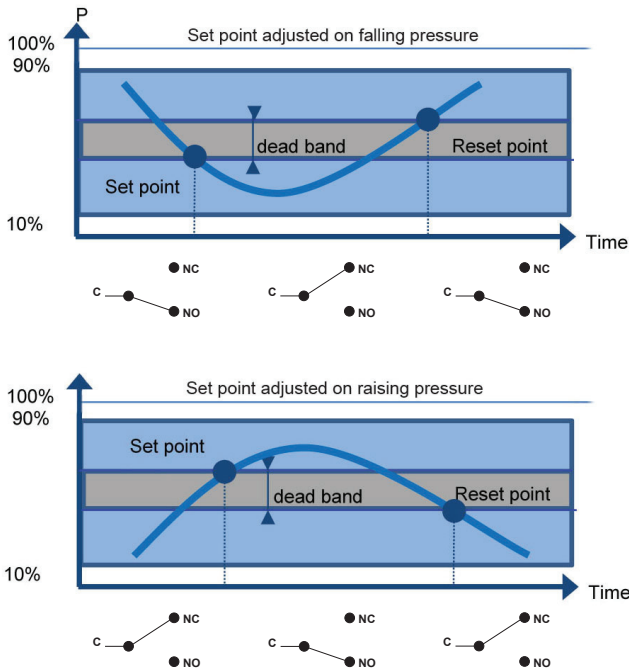

A flexible sensing element actuates a microswitch by means of a lever. The set point is adjusted by means of a compressible spring installed in opposition.

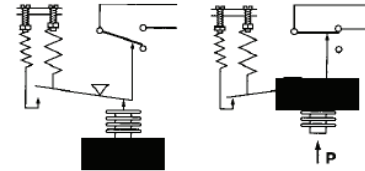

Set point and reset point must be between 10% and 90% of the selected scale.

Standard factory adjustment

Setpoint at 50% of the scale on falling pressure

Customer specific factory adjustment (option SETP)

The following specifications have to be given with the order:

- Setpoint value
- Adjustment on falling or raising pressure
- Dead band value (as needed) when using an adjustable dead band switch

Electrical connections

1 SPDT

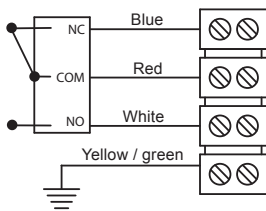

2 SPDT

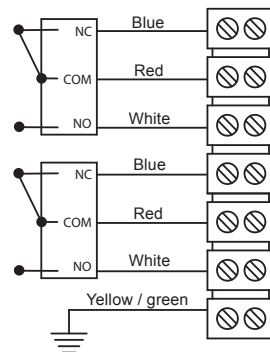

Micro switches characteristics

Switch code	A (B)	M (K)	C (W)	E (F)	H	D (V)	J
Type	Standard	Gold contact	Hermetic	Ultra sensitive	Manual reset	Ultra sensitive Hermetic	Manual reset
6 Vdc	0.4 ... 10 A	10 ... 50 mA	5 mA ... 4 A	0.4 ... 1 A	N/A	0.4 ... 4 A	N/A
12 Vdc	0.4 ... 10 A	10 ... 50 mA	5 mA ... 4 A	0.4 ... 1 A	N/A	0.4 ... 4 A	N/A
24 Vdc	0.4 ... 6 A	10 ... 50 mA	5 mA ... 4 A	0.4 ... 1 A	0.1 ... 8 A	0.4 ... 4 A	0.1 ... 8 A
30 Vdc	0.4 ... 6 A	10 ... 10 mA	5 mA ... 3 A	0.4 ... 1 A	0.1 ... 8 A	0.4 ... 2 A	0.1 ... 8 A
48 Vdc	0.4 ... 6 A	10 ... 50 mA	5 mA ... 3 A	N/A	0.1 ... 8 A	N/A	0.1 ... 8 A
110 Vdc	0.1 ... 0.5 A	10 ... 50 mA	5 mA ... 1 A	N/A	N/A	N/A	N/A
220 Vdc	0.1 ... 0.25 A	10 ... 50 mA	5 mA ... 0.5 A	N/A	N/A	N/A	N/A
115 Vac	0.4 ... 10 A	10 ... 50 mA	50 mA ... 3 A	0.4 ... 10 A	0.1 ... 10 A	N/A	0.1 ... 10 A
250 Vac	0.2 ... 10 A	10 ... 10 mA	50 mA ... 2.5 A	0.2 ... 10 A	0.1 ... 5 A	N/A	0.1 ... 5 A
Dielectric rigidity between contacts and ground	2000 V	2000 V	1500 V	2000 V	2000 V	1000 V	2000 V

Adjustable ranges

Scale	P. Max accidental	Code	Micro-switch dead band ¹⁾										
			Adjustable dead band				Fixed dead band						
			A (B*)		M (K*)		C (W*)		E (F*)		H	D (V*)	J
			10%	90%	10%	90%	10%	90%	10%	90%	10%	90%	
bar	bar		bar				mbar		bar				
-1 ... 2.5	80	201 ²⁾	0.25 - 2	0.3 - 2	0.8 - 2	1 - 2.5	65	75	0.3	0.35			
0.5 ... 10	50	204 ³⁾	0.18 - 3	0.25 - 3	0.63 - 3	0.80 - 3	45	62	0.25	0.3			
3.5 ... 25	100	205 ³⁾	0.45 - 10	0.9 - 10	1.5 - 10	3.1 - 10	150	200	0.55	1.1			
5 ... 50	100	206 ³⁾	1 - 10	2 - 10	3.5 - 10	7 - 10	200	300	1.5	2.5			
0.2 ... 4	50	210 ³⁾	0.1 - 3	0.18 - 3	0.35 - 3	0.63 - 3	40	50	0.15	0.25			

(*) When using 2 microswitches deadband lower values should be x1.5

¹⁾ The value of the deadband is depending on the value of the set point.

This table contains the deadband values for set point adjustment at 10% and 90% of the selected scale. For adjustable deadband the lower value corresponds to the deadband spring totally released and the higher corresponds to the deadband spring fully tensed. For other set points the deadband value can be calculated by linear interpolation between the values at 10% and 90%.

²⁾ For RPPN6 only.

³⁾ For RPPN8 only.

Dimensions (mm)

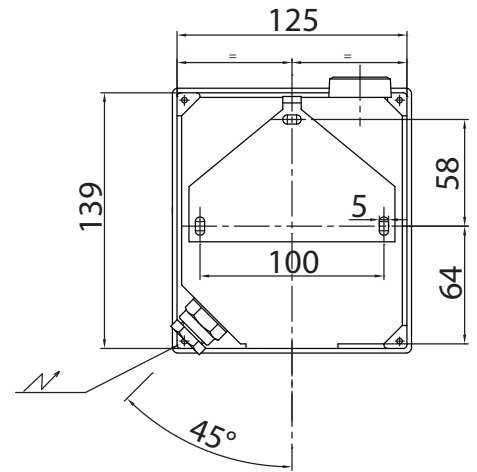
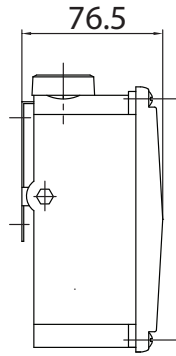
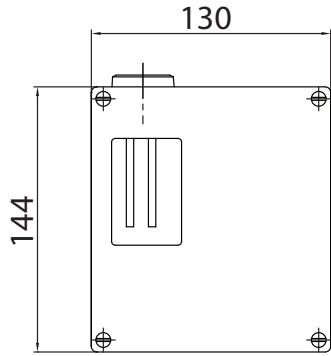

Pressure range code: 201
Weight: 2.4 kg

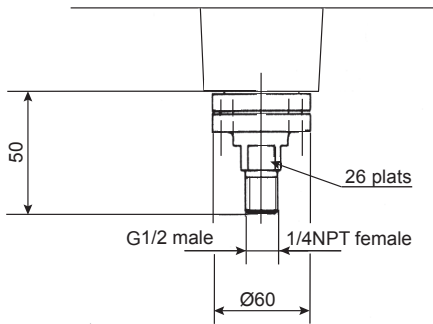

Pressure range code: 204 - 205 - 206 - 210
Weight: 2.4 kg

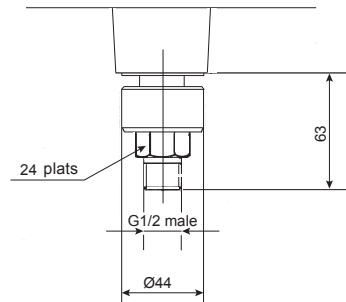

Ordering details RPPN6 - RPPN8

	RP	PN	-			.	xxx	/
Model								
Industrial pressure switch	RP							
Approvals								
Standard version without ATEX approval		PN						
Sensing element								
Diaphragm (Perbunan®, code 201)							6	
Diaphragm (Stainless steel, range 204 to 210)							8	
Type of micro switches								
Deadband								
1 SPDT standard changeover switch								A
2 SPDT standard changeover switch								B
1 SPDT hermetically changeover switch								C
2 SPDT hermetically changeover switch								W
1 SPDT ultra sensitive changeover switch								E
2 SPDT ultra sensitive changeover switch								F
1 SPDT hermetically, ultra sensitive changeover switch								D
2 SPDT hermetically, ultra sensitive changeover switch								V
1 SPDT gold contact changeover switch								M
2 SPDT gold contact changeover switch								K
1 SPDT changeover switch, manual reset, opening on raising pressure								H
1 SPDT changeover switch, manual reset, opening on falling pressure								J
Pneumatic changeover contact, NO								Z
Pneumatic changeover contact, NC								Y
Process connection								
G 1/2 male (standard)								3
1/2 NPT male								6
1/4 NPT female								8
Pressure range (bar)								
-1 ... 2.5 ¹⁾								201
0.5 ... 10 ²⁾								204
3.5 ... 25 ²⁾								205
5 ... 50 ²⁾								206
0.2 ... 4 ²⁾								210
Pressure range (kPa)								
-100 ... 250 ¹⁾								201
50 ... 1000 ²⁾								204
350 ... 2500 ²⁾								205
500 ... 5000 ²⁾								206
20 ... 400 ²⁾								210
Options to be added behind the / (see example below)								/

¹⁾ RPPN6 only
²⁾ RPPN8 only

Ordering example with options

	RP	PN	-	6	A	3	.	201	/	0407	_	9941
Industrial pressure switch	RP											
Without ATEX approval		PN										
Diaphragm Perbunan®				6								
1 SPDT standard changeover switch					A							
Process connection G 1/2 male						3						
Pressure range -1 ... 2.5 bar							.	201				
Option: Mounting on 2" pipe									/	0407		
Option: Stainless steel tag plate and wire											_	9941