

SPR-08

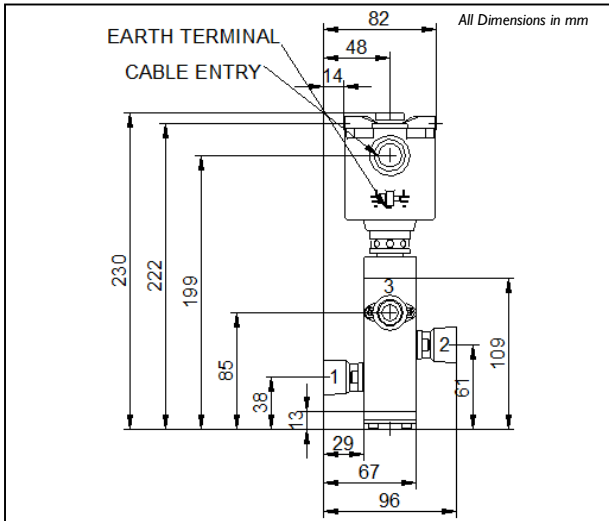

Dimensional Drawing



Schematic

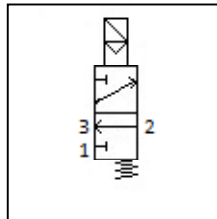

Wiring

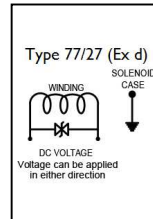

Rendering

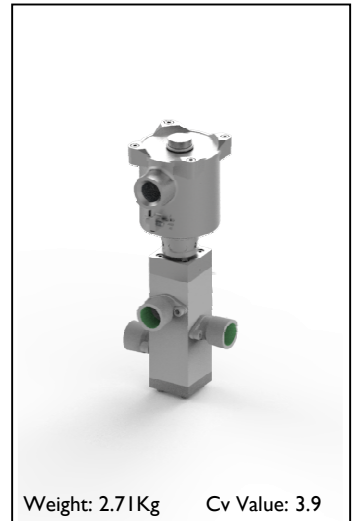

Certification



SPR-08-08-EI-32-NC-00-V-77A-24D-30

SPR-08	Pneumatic Spool Valve - Max 10 Bar Working Pressure	Model Code
08	1/2"	Ports
EI	Auto Reset - Internal Pilot	Primary Operator
32	3 Port - 2 Position	Configuration
NC	Normally Closed	Configuration
00	Spring Return	Secondary Operator
V	Viton -20°C to +100°C	Seals
77	Exd Solenoid	Solenoid
A	ATEX/IECEX Dual Certified/Labelled	Solenoid Approval
24D	24VDC	Voltage
30	3.0 Watt	Power
	M20 Cable Entry Entry	Cable Entry
	NPT Ports	Thread Form
	IPV	FP03P Operator
SPR-08-08-EI-32-NC-00-V-77A-24D-30		Model Number

Solenoid T-Rating

Ex d IIC Gb	T4 T135°C	(-60°C ≤ Tamb ≤ +90°C)
Ex tb IIIC Db	T5 T100°C	(-60°C ≤ Tamb ≤ +55°C)
	T6 T85°C	(-60°C ≤ Tamb ≤ +40°C)

This is a bespoke datasheet. For further details on the complete range, please refer to catalogue: Direct & Indirect Acting Solenoid Valves Models FP03P, FP06P, FP10P, FP12P, BXS & SPR

This valve is supplied to product revision 4 PR0022 13/01/2014
Details of the product revision are available on request.

Accuracy of information
We take care to ensure that product information in this catalogue is reasonably accurate and up-to-date. However, our products are continually developed and updated so to ensure accurate and up-to-date information please refer to the product catalogue issue list on our web site or contact a member of our sales team.

When selecting a product, the applicable operating system design must be considered to ensure safe use. The products function, material compatibility, adequate ratings, correct installation, operation and maintenance are the responsibilities of the system designer and user.

Quality Assurance
All Bifold products are manufactured to a most stringent QA programme to ensure that every product will give optimum performance and reliability. We are third party certified to BS EN ISO 9001:2008. Functional test certificates, letter of conformity and copies of original mill certificates, providing total traceability are available on request, to BS EN 10204 3.1 where available. We reserve the right to make changes to the specifications and design etc., without prior notice.

